



MySpot 30 Foot-Operated Locking Parking Barrier

MySpottm 30 is an attractive, hinged barrier that restricts access to an individual parking space. The barrier is unlocked by the use of a key; the key is removed and the barrier is pushed to the ground using a foot. The barrier locks in place on the ground to allow car entrance to the space.



MySpot 30 guards individual parking spaces

To raise the barrier after the car leaves, the user steps on a pedal. This releases the barrier from its ground lock, and it rises on its own power to the vertical position where it self-locks. Once locked in the vertical position, the user needs a key to release the lock. The pedal is designed so that a car tire will not accidentally release the barrier.

MySpot 30 is constructed using high grade, heavy duty durable steel tubing. All parts are treated with rust protection and are powder coated with outdoor paint. The mounting bases are constructed of 3mm steel, with 14mm hinges for extra strength. (5) M8 bolts anchor the unit to the ground for resistance to car abuse. Optional kits provide special security bolts along with a suitable wrench to remove these bolts. Other kits provide mounting hardware for asphalt.



The barrier is released from its locked down position by foot

The unit is shipped assembled, ready to be bolted to the parking surface. The kit includes 2 keys and an instruction manual. The supplied Euro lock can be replaced in the field for special keying requirements.

Applications

- Reserving designated parking spaces in garages, offices, shopping centers, hospitals, condominiums
- Blocking access to narrow streets and driveways
- Valet parking
- Handicap parking
- Parking lot management

Patents and Trademarks

MySpot 30 design and the concepts behind it are covered by US and world-wide patent applications.

MySpot and **EzUp** are trademarks of Designated parking Corp.

Turn to page 2



10 Ridge Rd
West Orange, NJ 07052
USA

Tel: 1.973.669.8214
Fax: 1.973.669.5161
Email: info@dp-corp.com
WEB: www.dp-corp.com



MySpot 30 Page 2

Installation

The MySpot 30 should be installed on a solid surface such as concrete or masonry. Installation on asphalt requires special hardware. Please visit our web site www.designatedparking.com for information under "Products > Accessories".

The actual installation in concrete requires drilling 5 x 10mm (3/8") holes, inserting the concrete anchors, placing the pre-assembled barrier and tightening the nuts.

Dimensions

The barrier stands 56 cm (22") high when erect. With the barrier locked down, the height of the assembly is only 7.5 cm (3"). This is low enough to offer adequate clearance for 99% of the vehicles on the road.

The barrier width is about 65 cm (~26"). It is installed in the middle of the space — both side to side and front to back.

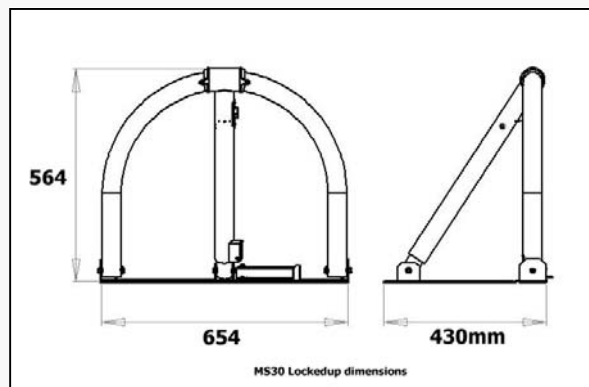

Warranty

All DP{C}'s products are warranted for 12 month from date of sale. Full terms and conditions available on our web [site](http://www.designatedparking.com).

| Optional Kits | Model |
|---|---------|
| 5 Concrete mounting anchors, M8 hex security bolts, washers, wrench | CA6/5 |
| 7 asphalt 14" anchors 3/8" female thread | SP14F/7 |
| Flexible adhesive to glue plate to surface | EPX1 |



MySpot 30 is pushed down, and raised, using your shoe. No more dirty hands or bending.

| P/N | Weight | carton | Warranty | Time to install |
|---------|-------------|---------------------|----------|-----------------|
| 01-6230 | 9Kg / 20lbs | 74x95x7cm 29"x39"3" | 1year | 30 minutes |



10 Ridge Rd
West Orange, NJ 07052
USA

Tel: 1.973.669.8214
Fax: 1.973.669.5161
Email: info@dp-corp.com
WEB: www.dp-corp.com